

PATIENT MEDICATION INFORMATION

READ THIS FOR SAFE AND EFFECTIVE USE OF YOUR MEDICINE

PrXOLAIR®

Omalizumab for injection - lyophilized powder for subcutaneous injection

Omalizumab injection - solution for subcutaneous injection

Read this carefully before you start taking Xolair® and each time you get a refill. This leaflet is a summary and will not tell you everything about this drug. Talk to your healthcare professional about your medical condition and treatment and ask if there is any new information about Xolair.

Keep this leaflet. You may need to read it again.

If you have further questions, please ask your healthcare professional.

Serious Warnings and Precautions

1- A severe allergic reaction called anaphylaxis can happen in some patients after receiving Xolair. Anaphylaxis is a life-threatening condition. Signs and symptoms of anaphylaxis include difficulty breathing, light-headedness, rash, itching, and swelling of the tongue and throat (see “Look out for signs of allergic reactions and other serious side effects” section).

Anaphylaxis from Xolair can happen as early as after the first injection or hours later, and/or after any Xolair injection. Your healthcare professional should watch you for some time for signs and symptoms of anaphylaxis after treatment is initiated. If you have any of the signs or symptoms of anaphylaxis, tell your doctor or nurse immediately, and get emergency medical treatment right away.

Your healthcare professional should instruct you about starting emergency medical treatment and getting further medical care if you have any signs or symptoms of anaphylaxis.

2- Weakness or paralysis of limbs or face, loss of sensation, difficulty speaking or understanding, transient loss of vision in one eye could be symptoms of a transient ischemic attack or stroke. Seek immediate medical attention if you experience any such symptoms.

What is Xolair used for?

Asthma

Adults and adolescents 12 years of age and older:

Xolair (omalizumab) is a prescription medicine that has been shown to significantly decrease the incidence of asthma exacerbations and improve control of asthma symptoms in people who:

- Are 12 years of age and above
- Have moderate to severe persistent asthma. This means they have 1 or more of the following:
 - Asthma symptoms every day
 - Daily need for a rescue inhaler
 - 2 or more asthma attacks a week

- 1 or more nights a week waking up with asthma symptoms
- below-normal reading (less than 80%) from a tool called a peak flow meter, which measures how well the lungs work
- Have asthma that is triggered by year-round allergens in the air, which is confirmed by a doctor using a simple skin or blood test. This is known as allergic asthma
- Continue to have asthma symptoms even though they are taking inhaled steroids

Children 6 to less than 12 years of age:

Xolair, used as add-on therapy, has been shown to significantly decrease the rate of asthma exacerbations for children who are 6 to less than 12 years of age with moderate to severe persistent allergic asthma who continue to have asthma symptoms even though they are taking inhaled steroids and have a documented history of asthma exacerbation.

Chronic Rhinosinusitis with Nasal Polyps (CRSwNP)

Xolair is used to treat adults (18 years of age and older) with chronic rhinosinusitis with nasal polyps (CRSwNP) whose disease is not well controlled with their current CRSwNP medicines. Xolair helps reduce the size of the polyps and improves symptoms caused by CRSwNP including nasal congestion, loss of sense of smell, post-nasal drip and runny nose.

Chronic Idiopathic Urticaria (CIU)

Xolair (omalizumab) is a prescription medicine to treat Chronic Idiopathic Urticaria (CIU) in adults and adolescents (12 years of age and older) whose symptoms are not well controlled with antihistamines. Xolair provides relief of CIU symptoms such as skin itch and hives.

How does Xolair work?

What is allergic asthma?

Allergic asthma is how doctors describe a particular type of asthma. In people with this common condition, certain types of allergens can trigger asthma attacks and symptoms, such as coughing, wheezing, and shortness of breath.

You probably know about many of the things that can trigger your asthma. Cat or dog dander, dust mites, and cockroaches are common examples of year-round allergens. What you may not know is how something as simple as visiting a friend who has a pet can lead to an asthma attack. The reason allergens can trigger asthma attacks is due, in part, to a body chemical called IgE.

What is Chronic Idiopathic Urticaria (CIU)

Chronic Idiopathic Urticaria (CIU) is a skin disease whose symptoms include itching and hives for at least 6 weeks. Persistent symptoms may be daily or episodic. Some people with CIU may also have swelling of the skin.

What is IgE?

IgE is short for immunoglobulin E. This substance, which occurs naturally in your body in small amounts, plays an important role in allergic asthma, CRSwNP and CIU.

If you have allergic asthma, your body makes more IgE when you breathe in an allergen that triggers your asthma. This can cause a series of chemical reactions known as the “allergic-inflammatory process in allergic asthma”. It can result in 2 things:

- The muscles that surround your airways begin to tighten. This is known as *constriction of the airways*
- Your airways become irritated and swell up. This is known as *inflammation of the airways*

Together, constriction and inflammation of the airways make it harder for you to breathe. This can lead to an asthma attack, also known as exacerbation.

Asthma and Chronic Rhinosinusitis with Nasal Polyps (CRSwNP)

Xolair blocks a substance called immunoglobulin E (also known simply as IgE) which is produced by your body. IgE contributes to a type of inflammation that plays a significant role in causing asthma and CRSwNP. Your doctor will measure the amount of IgE with a blood test and determine your body weight before starting the treatment with Xolair. By blocking IgE, Xolair helps stop the allergic-inflammatory process in allergic asthma.

Adding Xolair injections to treatment with inhaled steroids has been clinically proven to help reduce the number of asthma attacks. Xolair has not been proven to work in other allergic conditions.

Chronic Idiopathic Urticaria (CIU)

Xolair blocks a substance called immunoglobulin E (also known simply as IgE) which is produced by your body. By binding to IgE, Xolair reduces the activation of certain cells in your body and the release of histamine and other chemicals. This helps reduce symptoms of CIU, including itching and hives.

What are the ingredients in Xolair?

Medicinal ingredient: omalizumab

Non-medicinal ingredients: **Solution for injection in pre-filled syringe or pre-filled pen:** L-arginine hydrochloride, L-histidine, L-histidine hydrochloride monohydrate, polysorbate 20, water for injection.

Powder and solvent for solution for injection: histidine, histidine hydrochloride monohydrate, polysorbate 20 and sucrose.

Xolair comes in the following dosage forms:

Xolair is supplied as a powder in a small glass vial. The powder is dissolved in sterile water for injection before it is injected. Each vial delivers 150 mg of omalizumab. Xolair is also available as a ready to use solution in a pre-filled syringe or pre-filled pen. The pre-filled syringe or pre-filled pen are available in 75 mg, 150 mg and 300 mg of omalizumab.

Do not use Xolair if:

- If you are hypersensitive (allergic) to omalizumab or any of the other ingredients of Xolair (see above), or if you have ever had an allergic reaction to a Xolair injection.
- If you ever had an allergic reaction to latex (information specific to the needle cap of the pre-filled syringe).

To help avoid side effects and ensure proper use, talk to your healthcare professional before you take Xolair. Talk about any health conditions or problems you may have, including if you:

- Hypersensitivity reaction to any drug (see above **Do not use Xolair if**)
- Any other known hypersensitivity (see above **Do not use Xolair if**)
- Any allergies to this drug or its ingredients or components of the container (see above **What are the ingredients in Xolair and Do not use Xolair if**)
- If you ever had an allergic reaction to latex (information specific to the needle cap of the pre-

filled syringe).

- If you are living in a region where parasite infections are frequent or traveling to such a region, please tell your doctor. Xolair may weaken your resistance to such infections. If you are taking a treatment against parasite infection, please tell your doctor. Xolair may reduce the efficacy of your treatment.

Other warnings you should know about:

Xolair is not a rescue medicine and should not be used to treat sudden asthma attacks. It is not a substitute for the medicines you are already taking.

Use in children

Allergic asthma: Xolair is not indicated for children below 6 years of age.

Chronic Rhinosinusitis with Nasal Polyps (CRSwNP): Xolair is not indicated for children below 18 years of age.

Chronic idiopathic urticaria (CIU): Xolair is not indicated for children below 12 years of age.

Xolair 300 mg pre-filled syringe and all dose strengths of Xolair pre-filled pens are not intended for use in children under 12 years of age. Xolair 75 mg pre-filled syringe and Xolair 150 mg pre-filled syringe or Xolair powder and solvent for solution for injection may be used in children 6 to 11 years of age with allergic asthma.

Pregnancy

Ask your doctor, nurse or pharmacist for advice before taking any medicine.

Before starting treatment with Xolair, tell your doctor if you are pregnant or think that you may be pregnant. Your doctor will discuss with you the benefits and potential risks of being given this medicine during pregnancy. Tell your doctor straight away if you become pregnant while being treated with Xolair.

Breast-feeding

Ask your doctor, nurse or pharmacist for advice before being given any medicine.

Tell your doctor if you are breast-feeding. It is not known whether omalizumab, the active substance of Xolair, passes into breast milk or in what ways this could affect the baby. Your doctor will discuss with you the benefits and potential risks of being given this medicine while you are breast-feeding.

Fertility

There are no human fertility data for Xolair.

Driving and using machines

You may experience dizziness, sleepiness or fatigue after receiving Xolair, in which case you should not drive or use machines.

Tell your healthcare professional about all the medicines you take, including any drugs, vitamins, minerals, natural supplements or alternative medicines.

The following may interact with Xolair:

Please inform your doctor or nurse if you are taking or have recently taken any other medicines, even those not prescribed. Never suddenly stop taking, or change the dose of, your inhaled steroids or any other asthma medicine or of current medicine for CIU you are taking unless your doctor tells you to do so.

Xolair can be used together with other medicines for asthma and/or CRSwNP, as well as with H1 or H2 antihistamines and leukotriene receptor antagonists (LTRAs) for CIU, but it is still important to tell your doctor that you are taking them before you are given Xolair.

How to take Xolair:

Xolair is used as an injection under your skin (known as a subcutaneous injection).

The injection using the powder for solution for injection formulation is only supposed to be given by a healthcare professional.

Injecting Xolair pre-filled syringe and pre-filled pen

- You and your doctor will decide if you should inject Xolair yourself. The first 3 doses are given by or under the supervision of a healthcare professional (see **Serious Warnings and Precautions** box).
- It is important to be properly trained on how to inject the medicine before injecting yourself.
- A caregiver (for example a parent) may also give you your Xolair injection after he or she has received proper training.

For detailed instructions on how to inject Xolair, see “**Instructions for use of Xolair pre-filled syringe**” or “**Instructions for use of Xolair pre-filled pen**” at the end of this section.

Training to recognize serious allergic reactions

It is also important that you do not inject Xolair yourself until you have been trained by your healthcare professional on:

- how to recognize the early signs and symptoms of serious allergic reactions.
- what to do if the signs occur.

For more information about the early signs and symptoms of serious allergic reactions, see “**Look out for signs of allergic reactions and other serious side effects**” section.

A patient support program has been established to provide you with injection services. Contact your doctor to enroll.

Asthma

Based on your dose, your doctor will also tell you if you will need 1, 2, or 3 injections per dose. If you need more than 1 injection per dose, each will be given in a different area of your body.

You will receive 75, 150, 225 or 300 mg every four weeks, or 225, 300 or 375 mg every two weeks. You will probably need to continue taking your current asthma medicine during Xolair treatment but after 16 weeks you may be able to reduce or stop any other asthma medication that you are taking. Your doctor will discuss this with you. You should not reduce the dose of other asthma medication without first discussing with your doctor, even if you are feeling better.

Chronic Rhinosinusitis with Nasal Polyps (CRSwNP)

You will need 1 to 4 injections at a time. You will need the injections either every two weeks or every four weeks as prescribed by your doctor.

Keep taking your current CRSwNP medicine during Xolair treatment. Do not stop taking any CRSwNP medications without talking to your doctor.

Chronic Idiopathic Urticaria (CIU)

Xolair 150 mg or 300 mg are administered subcutaneously every 4 weeks. The efficacy of Xolair in CIU patients depends on the quantity that is injected.

Usual dose:

Asthma and Chronic Rhinosinusitis with Nasal Polyps (CRSwNP)

Xolair is given once every 2 or 4 weeks. Your dose will be determined by your body weight and your IgE level, which your doctor will measure with a simple blood test. Based on your dose, your doctor will also tell you if you will need 1, 2, 3 or 4 injections per dose. If you need more than 1 injection, each will be given in a different place on your body.

Because it is a controller or *maintenance medicine*, you will receive Xolair on a regular schedule. It is important that you continue to receive your Xolair injections even when you are feeling well.

Chronic Idiopathic Urticaria (CIU)

You will be given 1 or 2 injections at a time every 4 weeks.

Continue taking your current medicine for CIU during Xolair treatment. Do not stop taking any medicine without talking to your doctor first.

Continue to use Xolair for as long as your doctor tells you to do so.

If you have questions about how long to receive Xolair, talk to your doctor or your pharmacist.

Overdose:

The maximum tolerated dose of Xolair has not been determined. Single intravenous doses up to 4000 mg have been administered to patients without evidence of dose-limiting toxicities. In case of overdosage, it is recommended that the patient be monitored for any signs or symptoms of adverse reactions or effects and appropriate symptomatic treatment instituted immediately.

If you think you, or a person you are caring for, have taken too much Xolair, contact a healthcare professional, hospital emergency department, or regional poison control centre immediately, even if there are no symptoms.

Missed Dose:

If you have missed an appointment to get a Xolair injection, contact your doctor and get it as soon as you remember.

If you have forgotten a dose of Xolair, inject the dose as soon as you remember. Then talk to your doctor to discuss when to inject the next dose.

Instructions for use - Xolair solution for injection in pre-filled syringe (pre-filled syringe with 26-gauge staked needle)

Read ALL the way through these instructions before injecting. If your doctor decides that you or a caregiver may be able to give your injections of Xolair at home, you need to be trained by your healthcare professional before you inject yourself or others. Children (6 to less than 12 years of age) are not expected to inject Xolair themselves, however, if deemed appropriate by their doctor, a caregiver may give them their Xolair injection after proper training. The box contains Xolair pre-filled syringe(s) individually sealed in a plastic tray.

Xolair pre-filled syringe is available in two strengths, 75 mg and 150 mg. You may receive one or both strengths from the pharmacy.

Your Xolair 75 mg pre-filled syringe before use (blue)

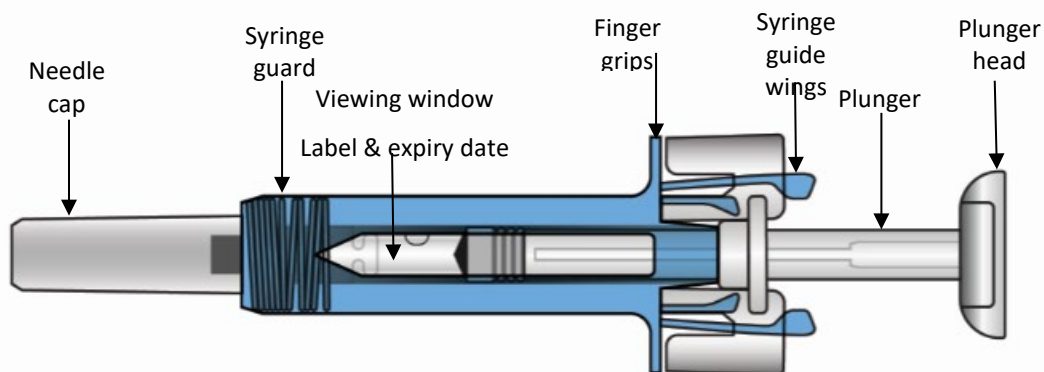

Your Xolair 75 mg pre-filled syringe after use (blue)

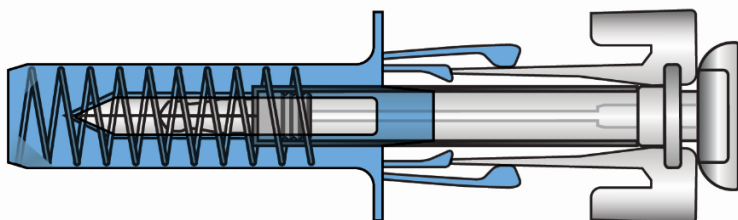

After the medicine has been injected the syringe guard will be activated to cover the needle. This is intended to protect against accidental needle stick injuries.

Your Xolair 150 mg pre-filled syringe before use (purple)

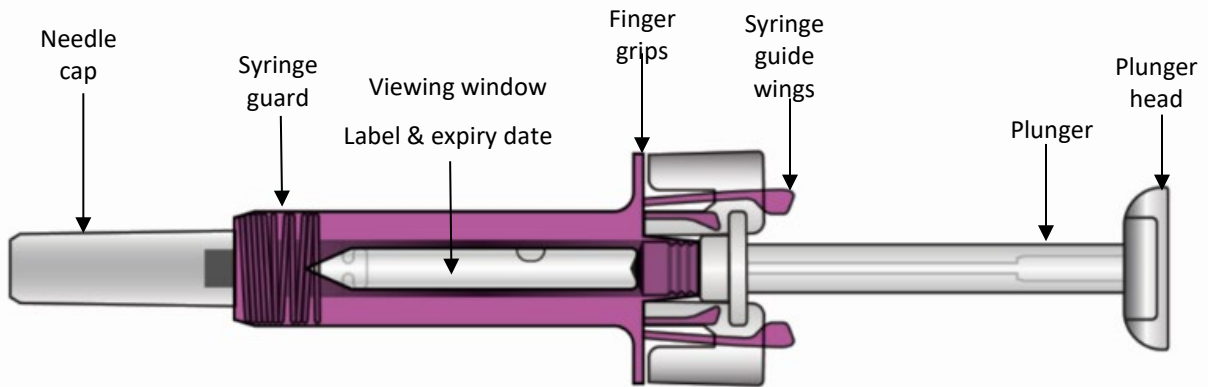

Your Xolair 150 mg pre-filled syringe after use (purple)

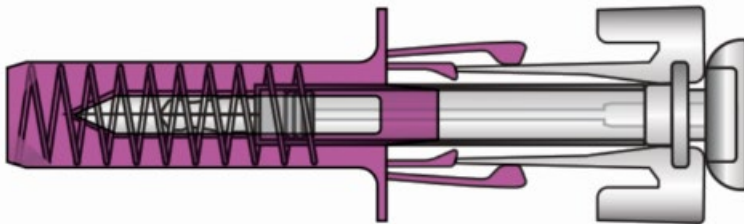

After the medicine has been injected the syringe guard will be activated to cover the needle. This is intended to protect against accidental needle stick injuries.

Other items you need for your injection:

- Alcohol swab.
- Cotton ball or gauze.
- Sharps disposal container.

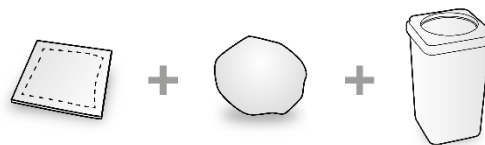

Important safety information

Caution: Keep the syringe out of the sight and reach of children.

- The needle cap of the syringe may contain dry rubber (latex), which should not be handled by anyone who is sensitive to this substance.
- Do not open the sealed outer box until you are ready to use this medicine.
- Do not use this medicine if either the seal on the outer box or the seal of the plastic tray is broken, as it may not be safe for you to use.
- Do not use if the syringe has been dropped onto a hard surface or dropped after removing the needle cap.
- Never leave the syringe where others might tamper with it.
- Do not shake the syringe.
- Be careful not to touch the syringe guard wings before use. If the wings are touched, the syringe guard may be activated too early.

- Do not remove the needle cap until just before you give the injection.
- The syringe cannot be re-used. Dispose of the used syringe immediately after use in a sharps container.

Storage of the Xolair pre-filled syringe





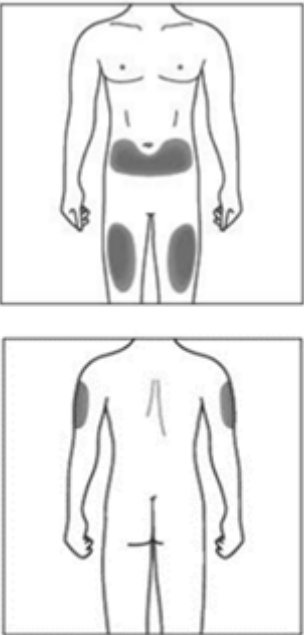



- Store this medicine sealed in its outer box to protect it from light. Store in the refrigerator between 2 and 8°C. DO NOT FREEZE.
- Remember to take the syringe out of the refrigerator and allow it to reach room temperature (25°C) before preparing it for injection (about 30 minutes). Leave the syringe in the box to protect it from light. If necessary, the product may be returned to the refrigerator for later use. The total time that the syringe is kept at room temperature (25°C) before use must not exceed 2 days (48 hours).
- Do not use the syringe after the expiry date which is stated on the outer box and syringe label. If it has expired, return the entire pack to the pharmacy.

The injection site

	<p>The injection site is the place on the body where you are going to use the syringe.</p> <ul style="list-style-type: none"> • The recommended site is the front of the thighs. You may also use the lower abdomen, but not the area 5 centimeters around the navel (belly button). • If you need to give more than one injection for the full dose, choose a different injection site each time you inject. • Do not inject into areas where the skin is tender, bruised, red, or hard. Avoid areas with scars or stretch marks. If a caregiver is giving the injection, the outer upper arms may also be used. Do not try to inject into the upper arm area by yourself.
--	---



Preparing the Xolair pre-filled syringe for use

Note: Xolair pre-filled syringes are available in 2 dose strengths. Depending on the dose prescribed to you by your doctor, you may need to prepare one or more pre-filled syringes, and inject the contents of them all. The following table gives examples of how many injections of each dose strength you need for a given dose:

Dose	Syringes needed for the dose		
75 mg	1 blue (75 mg)		
150 mg	1 purple (150 mg)		
225 mg	1 blue (75 mg)	+ 1 purple (150 mg)	
300 mg	2 purple (150 mg)		
375 mg	1 blue (75 mg)	+ 2 purple (150 mg)	
450 mg	3 purple (150 mg)		
525 mg	1 blue (75 mg)	+ 3 purple (150 mg)	
600 mg	4 purple (150 mg)		

1. Take the box containing the syringe out of the refrigerator and leave it **unopened** for about 20 minutes so that it reaches room temperature (leave the syringe in the box to protect it from light).
2. When you are ready to use the syringe, wash your hands thoroughly with soap and water.
3. Clean the injection site with an alcohol swab.
4. Remove the plastic tray from the box and peel back the paper cover. Gripping the middle of the syringe guard, lift the syringe out of the tray.
5. Inspect the syringe. The liquid should be clear to slightly cloudy. Its color may vary from colorless to pale brownish-yellow. You may see an air bubble, which is normal. **DO NOT USE** if the syringe is broken or if the liquid looks distinctly cloudy or distinctly brown, or contains particles. In all these cases, return the entire pack to the pharmacy.
6. Holding the syringe horizontally, look into the viewing window to check the expiry date printed on the label. Note: It is possible to rotate the inner part of the syringe assembly so that the label can be read in the viewing window. **DO NOT USE** if the product has expired. If expired, return the entire pack to the pharmacy.

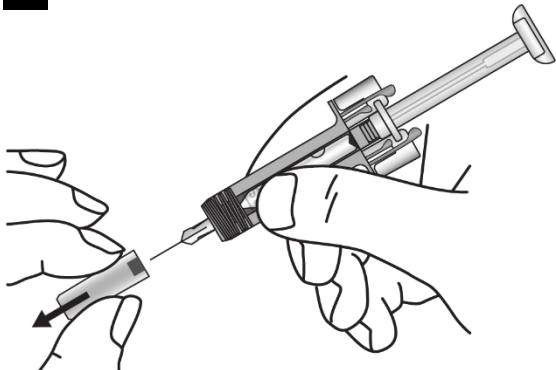
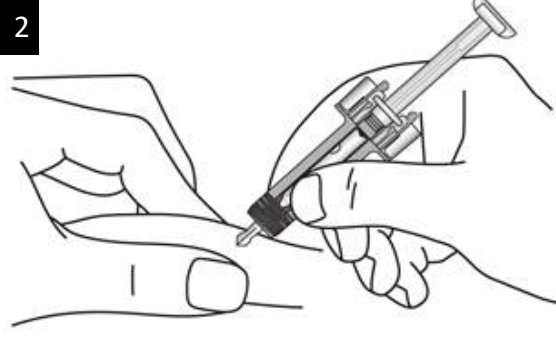
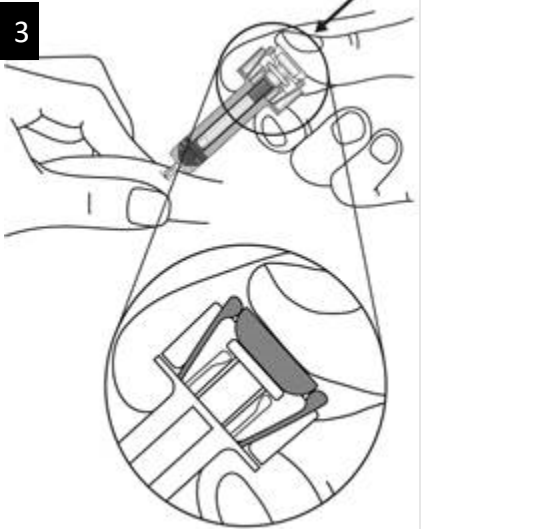
How to use the Xolair pre-filled syringe

<p>1</p> 	<p>Carefully remove the needle cap from the syringe. Discard the needle cap. You may see a drop of liquid at the end of the needle. This is normal.</p>
<p>2</p> 	<p>Gently pinch the skin at the injection site and insert the needle as shown. Push the needle all the way in to ensure that the medicine can be fully administered.</p>
<p>3</p> 	<p>Hold the syringe as shown. Slowly depress the plunger as far as it will go so that the plunger head is completely between the syringe guard wings.</p>
<p>4</p> 	<p>Keep the plunger fully depressed while you carefully lift the needle straight out from the injection site.</p>

<p>5</p> 	<p>Slowly release the plunger and allow the syringe guard to automatically cover the exposed needle. There may be a small amount of blood at the injection site. You can press a cotton ball or gauze over the injection site and hold it for 30 seconds. Do not rub the injection site. You may cover the injection site with a small adhesive bandage, if needed.</p>
--	---

If your prescribed dose requires more than 1 injection:

- Throw away the used pre-filled syringe as described in the disposal instructions below.
- Repeat the preparation and injection steps for the next injection using a new pre-filled syringe.
- Choose a different injection site for each new injection at least 2.5 cm from other injection sites.
- Complete all the required injections for your prescribed dose, immediately one after another. Contact your healthcare provider if you have any questions.

Disposal instructions

	<p>Dispose of the used syringe immediately in a sharps container (closable, puncture resistant container). For the safety and health of you and others, needles and used syringes must never be re-used. Any unused medicinal product or waste material should be disposed of in accordance with local requirements. Do not throw away any medicines via wastewater or household waste. Ask your pharmacist how to throw away medicines you no longer use. These measures will help protect the environment.</p>
---	---

Instructions for use - Xolair solution for injection in pre-filled syringe (pre-filled syringe with 27-gauge staked needle)

This “Instructions for Use” contains information on how to inject Xolair solution for injection in a pre-filled syringe with a 27-gauge staked needle.

If your doctor decides that you or your caregiver may be able to give your injections of Xolair at home, ensure that your doctor or nurse shows you or your caregiver how to prepare and inject with the Xolair pre-filled syringe before you use it for the first time.

Children below 12 years of age are not expected to inject Xolair themselves, however, if deemed appropriate by their doctor, a caregiver may give them their Xolair injections after proper training.

Be sure that you read and understand this “Instructions for Use” before injecting with the Xolair pre-filled syringe. Talk to your doctor if you have any questions.

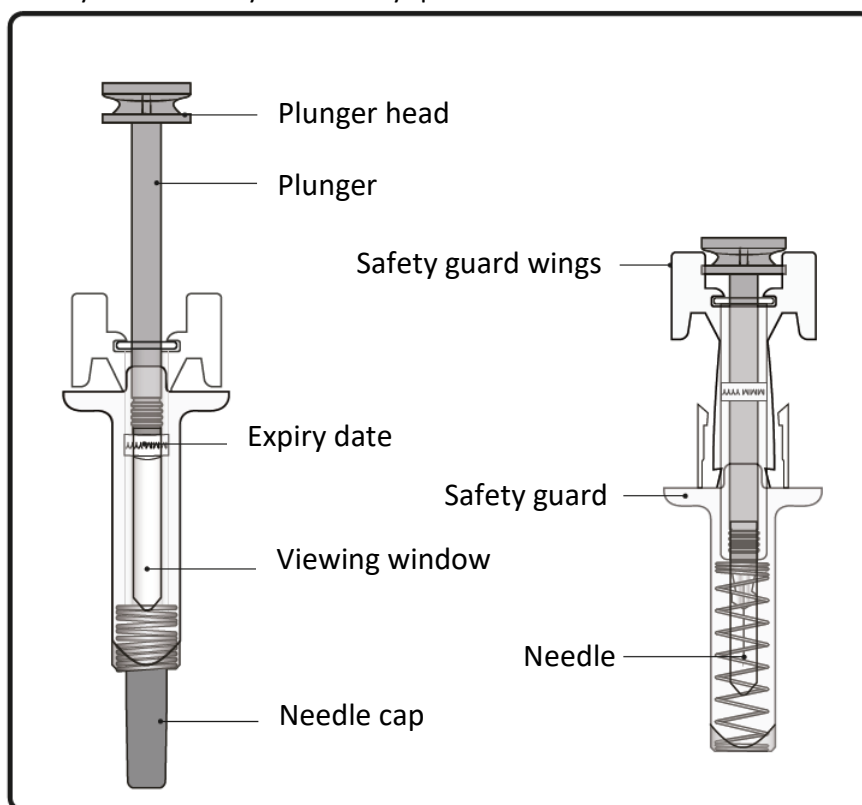

Important information you need to know before injecting Xolair

- Xolair is for subcutaneous injection only (inject directly into fatty layer under the skin).
- **Do not** use the pre-filled syringe if either the seal on the outer carton or the seal of the plastic tray is broken.
- **Do not** use if the pre-filled syringe has been dropped onto a hard surface or dropped after removing the needle cap.
- **Do not** inject if the pre-filled syringe has been kept out of the refrigerator for more than a total of 48 hours. Dispose of it (see Step 12) and use a new pre-filled syringe for your injection.

- The pre-filled syringe has a safety guard that will be activated to cover the needle after the injection is finished. The safety guard will help to prevent needlestick injuries to anyone who handles the pre-filled syringe after injection.
- **Do not** try to re-use or take apart the pre-filled syringe.
- **Do not** pull back on the plunger.

Store Xolair

- Store in a refrigerator (2 to 8°C). The carton containing the pre-filled syringe can be stored for a total time of 48 hours at room temperature (25°C) before use. It can be placed back in the refrigerator if necessary.
- **Do not** freeze.
- Keep the pre-filled syringe in the original carton until ready to use in order to protect from light.
- Keep the pre-filled syringe out of sight and reach of children.

Dosing table

Xolair pre-filled syringes are available in 3 dose strengths (one pre-filled syringe in each carton). These instructions are to be used for all 3 dose strengths.

Depending on the dose prescribed to you by your doctor, you may need to select one or more pre-filled syringes, and inject the contents of them all in order to deliver your full dose. The Dosing Table below shows the combination of pre-filled syringes needed to deliver your full dose.

	<p>Important: If the dose is for a child under age 12 it is recommended to use only blue (75 mg) and purple (150 mg) pre-filled syringes. Refer to the Dosing Table below for the recommended combination of pre-filled syringes for children under age 12.</p>
---	--

Contact your doctor if you have questions on the Dosing Table.

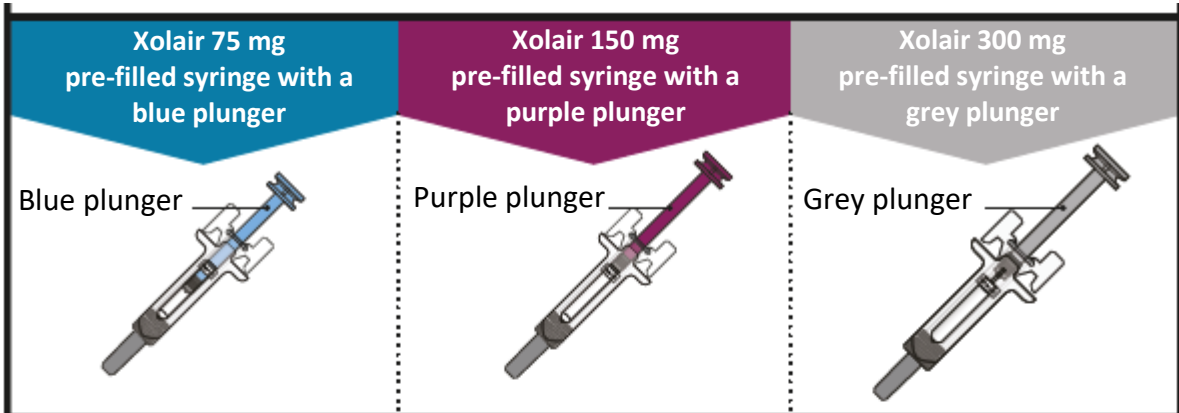

DOSE	Pre-filled syringes needed for dose	Blue 75 mg	Purple 150 mg	Grey 300 mg
75 mg	1 blue			
150 mg	1 purple			
225 mg	1 blue + 1 purple			
300 mg (ages 12 and up)	1 grey			
300 mg (children under age 12)	2 purple			
375 mg (ages 12 and up)	1 blue + 1 grey			
375 mg (children under age 12)	1 blue + 2 purple			
450 mg (ages 12 and up)	1 purple + 1 grey			
450 mg (children under age 12)	3 purple			
525 mg (ages 12 and up)	1 blue + 1 purple + 1 grey			
525 mg (children under age 12)	1 blue + 3 purple			
600 mg (ages 12 and up)	2 grey			
600 mg (children under age 12)	4 purple			

Prepare to inject Xolair

Step 1. Bring to room temperature

Take the carton containing the pre-filled syringe out of the refrigerator **and leave it unopened so that it reaches room temperature (minimum 30 minutes)**.

Note: If you need more than one pre-filled syringe (one pre-filled syringe per carton) to deliver your full dose (See Dosing Table), take all the cartons out of the refrigerator at the same time.

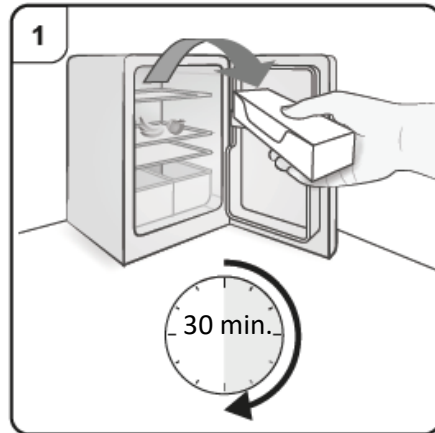

Step 2. Gather supplies

You will need the following supplies (not included in the carton):

- Alcohol wipe
- Cotton ball or gauze pad
- Sharps disposal container
- Adhesive plaster

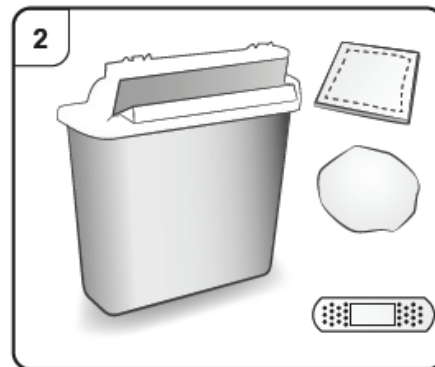

Step 3. Unpack

Open the plastic tray by peeling away the cover. Remove the pre-filled syringe by holding it in the middle as shown.

Do not remove the needle cap until you are ready to inject.

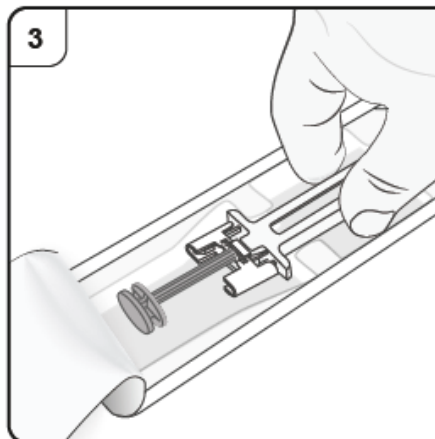

Step 4. Inspect the pre-filled syringe

Look through the viewing window of the pre-filled syringe.

The liquid inside should be clear to slightly cloudy. Its color may vary from colorless to pale brownish-yellow. You may see air bubbles in the liquid, which is normal. **Do not** try to remove the air.

- **Do not** use the pre-filled syringe if the liquid contains particles, or if the liquid looks distinctly cloudy or distinctly brown.
- **Do not** use the pre-filled syringe if it looks damaged or if it has leaked.
- **Do not** use the pre-filled syringe after the expiry date (EXP), which is printed on the pre-filled syringe label and carton.

In all of these cases, contact your doctor, nurse or pharmacist.

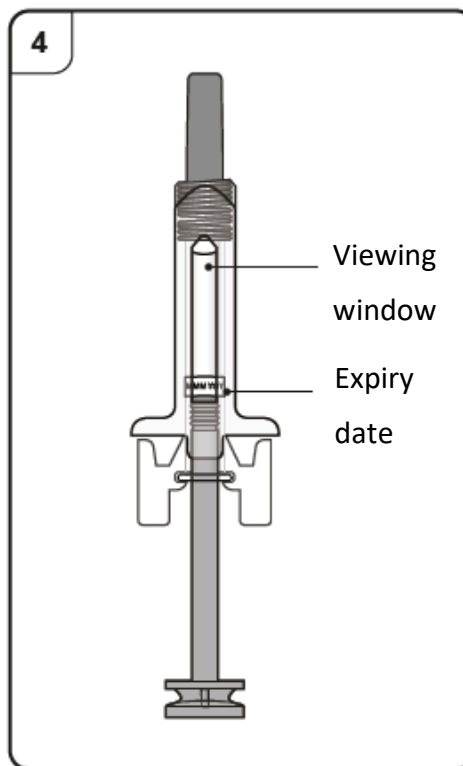

Step 5. Choose injection site

You should inject into the front of the thighs or the lower stomach area but not the area 5 cm around the belly button.

Do not inject into skin that is tender, bruised, red, scaly, hard or into areas with scars or stretch marks.

Note: If you need more than one pre-filled syringe to deliver your full dose, make sure your injections are at least 2 cm apart.

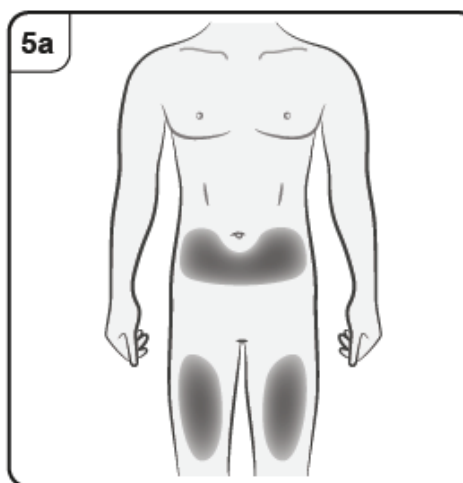

If your caregiver, doctor or nurse is giving you the injection, they may also inject into the outer upper arm.

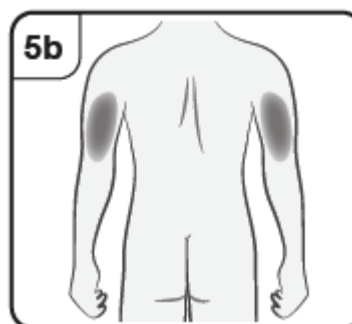

Inject with Xolair

Step 6. Clean injection site

Clean your hands.

Clean the chosen injection site with an alcohol wipe. Leave it to dry before injecting.

Do not touch or blow on the cleaned skin before injecting.

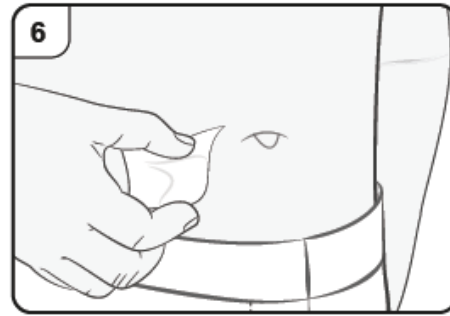

Step 7. Remove needle cap

Firmly pull straight to remove the needle cap from the pre-filled syringe. You may see a drop of liquid at the end of the needle. This is normal.

Do not put the needle cap back on.

Throw away the needle cap.

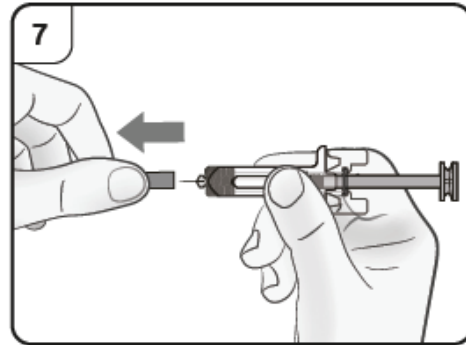

Step 8. Insert needle

Gently pinch the skin at the injection site and hold the pinch throughout the injection. With the other hand insert the needle into the skin at an angle of approximately 45 degrees as shown.

Do not press the plunger while inserting the needle.

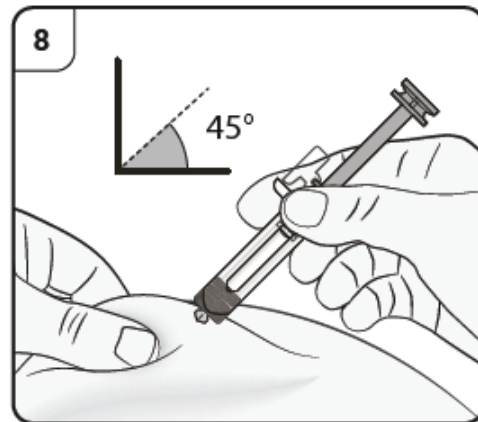

Step 9. Start injection

Continue to pinch the skin. Slowly press the plunger **as far as it will go**. This will ensure that a full dose is injected.

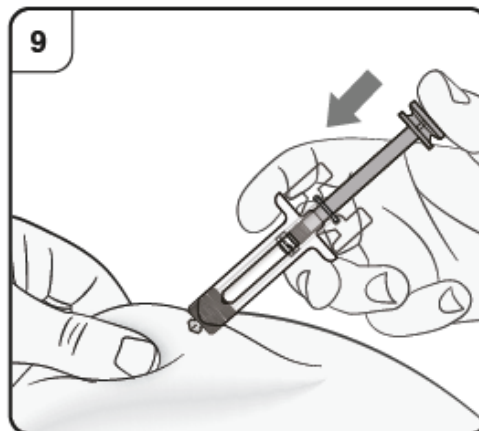

Step 10. Complete injection

Confirm that the plunger head is between the safety guard wings as shown. This will ensure that the safety guard has been activated and will cover the needle after the injection is finished.

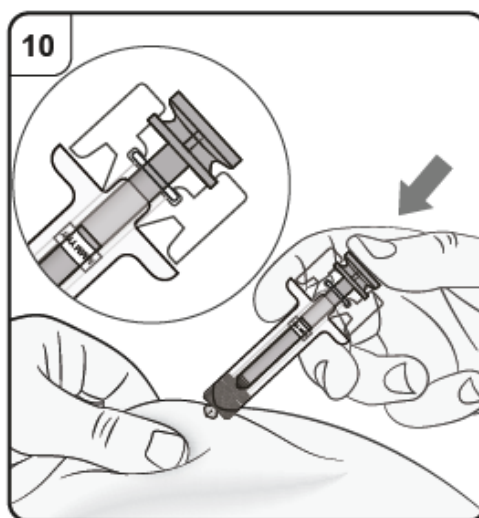

Step 11. Release plunger

Keeping the pre-filled syringe at the injection site, slowly release the plunger until the needle is covered by the safety guard. Remove the pre-filled syringe from the injection site and release the pinch.

There may be a small amount of blood at the injection site. You can press a cotton ball or gauze pad over the injection site until any bleeding stops. **Do not** rub the injection site. If needed, cover the injection site with a small adhesive plaster.

Note: If you need more than one pre-filled syringe to deliver your full dose, throw away the used pre-filled syringe as described in Step 12.

Repeat Step 2 to Step 12 again for all the pre-filled syringes needed to deliver your full dose.

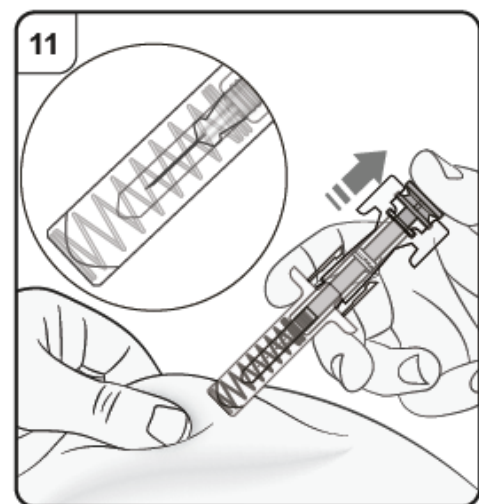

Carry out the injections immediately one after another.

Make sure the injections are at least 2 cm apart.

After the injection

Step 12. Dispose of the pre-filled syringe

Put the used pre-filled syringe in a sharps disposal container (i.e. a puncture-resistant closable container, or similar) immediately after use.

Do not throw away the pre-filled syringe into household waste.

Do not try to put the needle cap back onto the syringe.

Talk to your doctor or pharmacist about proper disposal of the sharps disposal container. There may be local regulations for disposal.

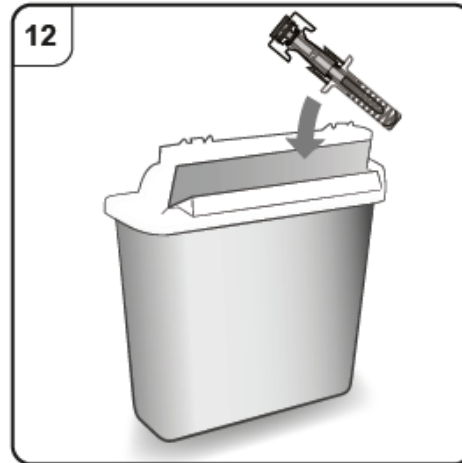

Instructions for use and handling - Xolair solution for injection in pre-filled pen

This “Instructions for Use” contains information on how to inject Xolair solution for injection in pre-filled pen.

If your doctor decides that you or your caregiver may be able to give your injections of Xolair at home, ensure that your doctor or nurse shows you or your caregiver how to prepare and inject with the Xolair pen before you use it for the first time.

This Xolair pen is intended to be used for patients ages 12 and up.

Be sure that you read and understand this “Instructions for Use” before injecting with the Xolair pen.

Talk to your doctor if you have any questions.

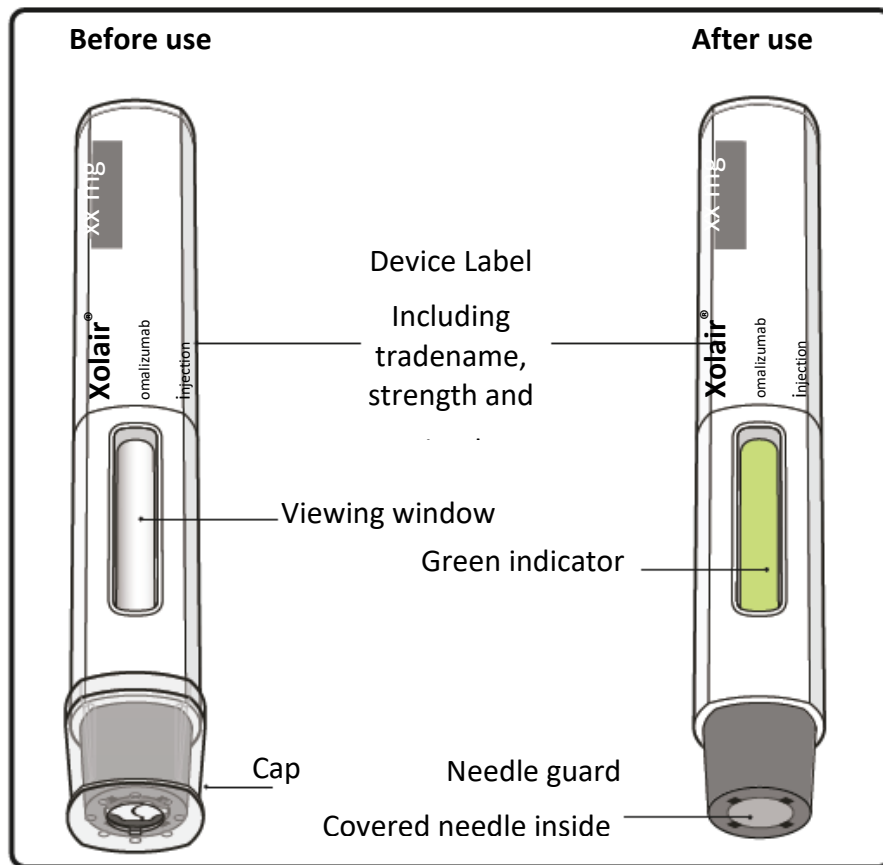

Important information you need to know before injecting Xolair

- Xolair is for subcutaneous injection only (inject directly into fatty layer under the skin).
- **Do not** use the pen if the seal on the outer carton is broken.
- **Do not** use if the pen has been dropped after removing the cap.
- **Do not** inject if the pen has been kept out of the refrigerator for more than a total of 48 hours. Dispose of it (see Step 13) and use a new pen for your injection.
- **Do not** touch or push the needle guard as you could get injured. Touching or pushing on the needle guard could cause a needlestick injury.
- **Do not** try to re-use or take apart the pen.
- **Do not** try to reattach the cap once it has been taken off.

Store Xolair











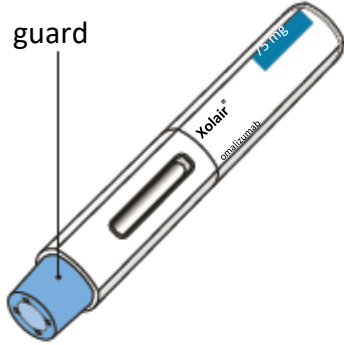
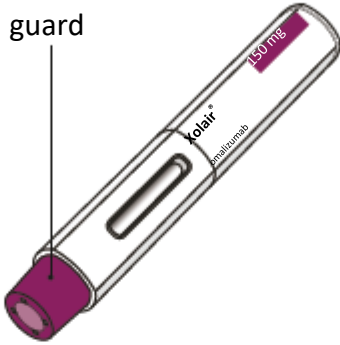
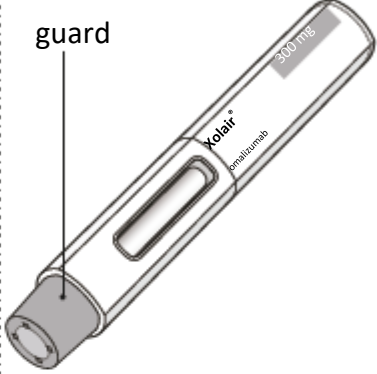



- Store in a refrigerator (2 to 8°C). The carton containing the pen can be stored for a total time of 48 hours at room temperature (25°C) before use. It can be placed back in the refrigerator if necessary.
- **Do not** freeze.
- Keep the pen in the original carton until ready to use in order to protect from light.
- Keep the pen out of sight and reach of children.

Dosing table

Xolair pens are available in 3 dose strengths (one pen in each carton). These instructions are to be used for all 3 dose strengths.

Depending on the dose prescribed to you by your doctor, you may need to select one or more pens, and inject the contents of them all in order to deliver your full dose. The Dosing Table below shows the combination of pens needed to deliver your full dose.

Contact your doctor if you have questions on the Dosing Table.

		Xolair 75 mg pen with a blue needle guard	Xolair 150 mg pen with a purple needle guard	Xolair 300 mg pen with a grey needle guard
Blue needle guard			Purple needle guard	Grey needle guard
Purple needle guard				
Grey needle guard				
Dose	Number of pens needed for the dose	Blue 75 mg	Purple 150 mg	Grey 300 mg
75 mg	1 blue			
150 mg	1 purple			
225 mg	1 blue + 1 purple			
300 mg	1 grey			
375 mg	1 blue + 1 grey			
450 mg	1 purple + 1 grey			
525 mg	1 blue + 1 purple + 1 grey			
600 mg	2 grey			

Prepare to inject Xolair

Step 1. Bring to room temperature

Take the carton containing the pen out of the refrigerator **and leave it unopened so that it reaches room temperature (minimum 30 minutes)**.

Note: If you need more than one pen (one pen in each carton) to deliver your full dose (see Dosing Table), take all the cartons out of the refrigerator at the same time.

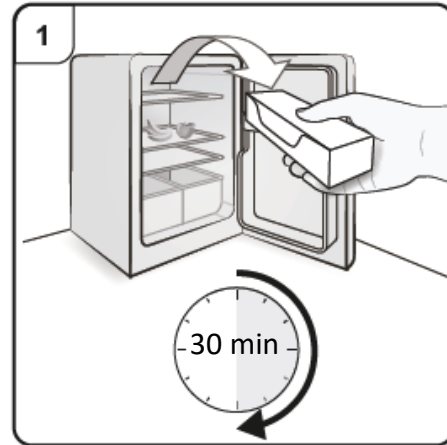

Step 2. Gather supplies

You will need the following supplies (not included in the carton):

- Alcohol wipe
- Cotton ball or gauze pad
- Sharps disposal container
- Adhesive plaster

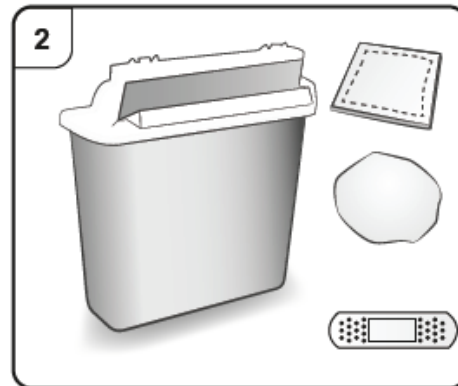

Step 3. Unpack

Take the pen out of the outer carton.

Do not remove the cap until you are ready to inject.

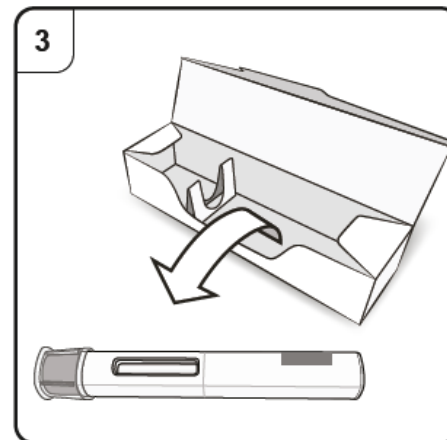

Step 4. Inspect the pen

Look through the viewing window of the pen. The liquid inside should be clear to slightly cloudy. Its color may vary from colorless to pale brownish-yellow. You may see air bubbles in the liquid, which is normal.

- **Do not** use the pen if the liquid contains particles, or if the liquid looks distinctly cloudy or distinctly brown.
- **Do not** use the pen if it looks damaged.
- **Do not** use the pen after the expiry date (EXP), which is printed on the pen label and carton.

In all of these cases, contact your doctor, nurse or pharmacist.

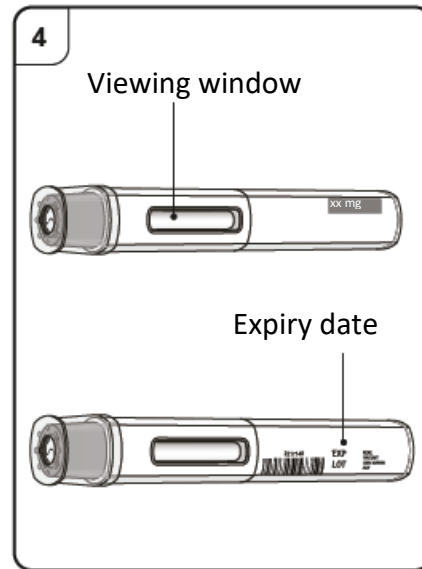

Step 5. Choose injection site

You should inject into the front of the thighs or the lower stomach area but not the area 5 cm around the belly button.

Do not inject into skin that is tender, bruised, red, scaly, and hard or into areas with scars or stretch marks.

Note: If you need more than one pen to deliver your full dose, make sure your injections are at least 2 cm apart.

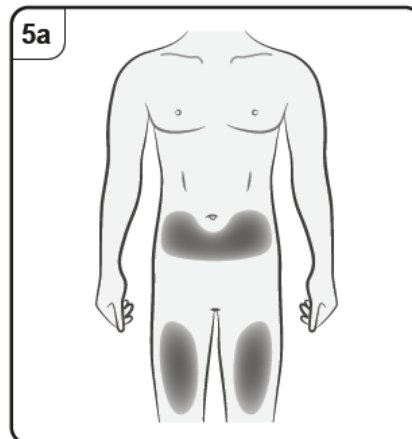

If a caregiver, doctor or nurse is giving the injection, they may also inject into the outer upper arm.

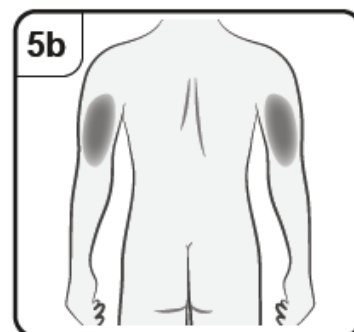

Inject with Xolair

Step 6. Clean injection site

Clean your hands.

Clean the chosen injection site with an alcohol wipe. Leave it to dry before injecting.

Do not touch or blow on the cleaned skin before injecting.

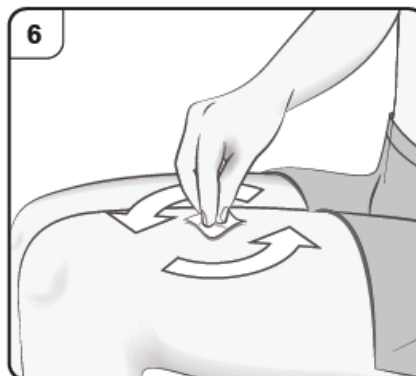

Step 7. Remove cap

Pull the cap straight off in the direction of the arrow.

Do not put the cap back on. Throw away the cap.

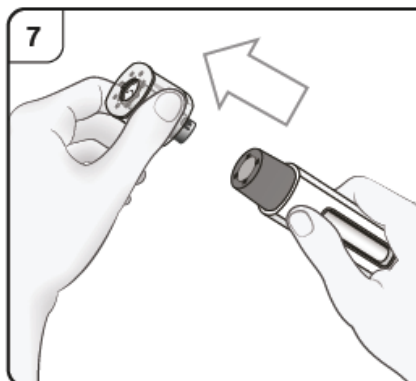

Step 8. Position the pen

Hold the pen comfortably **with the needle guard directly against the skin**.

The pen should be at a 90° angle to the skin as shown.

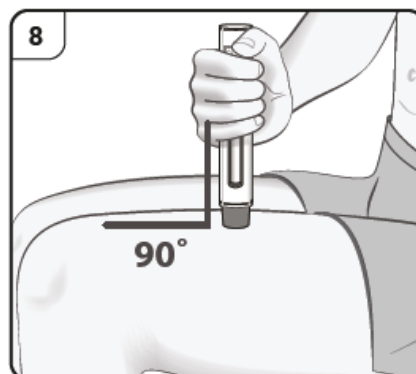

Step 9. Start injection

Push and hold the pen firmly against the skin. Listen for the **1st click** which indicates that the injection has started.

 Listen for 'click' sound.

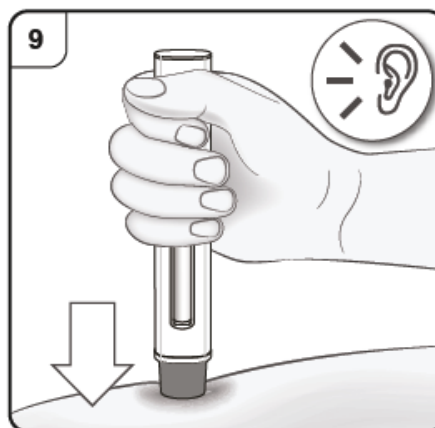

Step 10. Monitor injection

Keep holding the pen firmly down against the skin. The green indicator shows the progress of the injection.

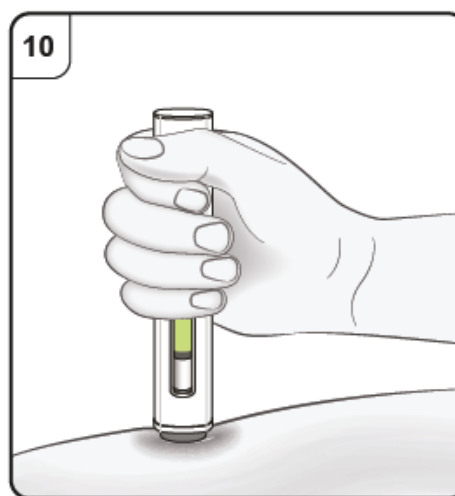

Step 11. Complete injection

Listen for the **2nd click**. This indicates the injection is **almost** complete.

Keep holding the pen in position until the green indicator has stopped moving to make sure the injection is complete. Remove the pen from the skin. The needle is automatically covered by the needle guard. The injection is now complete.

 Listen for 'click' sound.

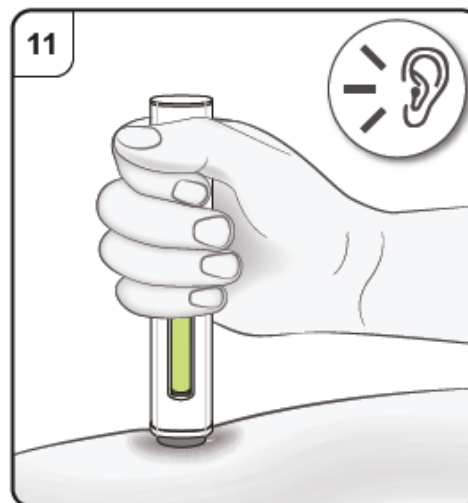

After the injection

Step 12. Check green indicator

If the green indicator has not completely filled the viewing window, contact your doctor or nurse.

There may be a small amount of blood at the injection site.

You can press a cotton ball or gauze pad over the injection site until any bleeding stops.

Do not rub the injection site. If needed, cover your injection site with a small adhesive plaster.

Note: If you need more than one pen to deliver your full dose, throw away the used pen as described in Step 13.

Repeat Step 2 to Step 13 again for all the pens needed to deliver your full dose.

Carry out the injections immediately one after another.

Make sure the injections are at least 2 cm apart.

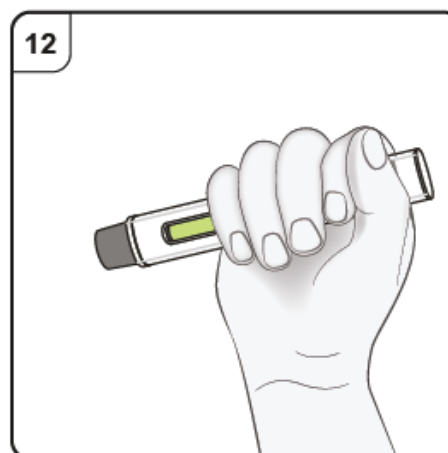

Step 13. Dispose of the pen

Put the used pen in a sharps disposal container (i.e. a puncture-resistant closable container, or similar) right away after use.

Do not throw away (dispose of) the pen into household waste.

Talk to your doctor or pharmacist about proper disposal of the sharps disposal container. There may be local regulations for disposal.

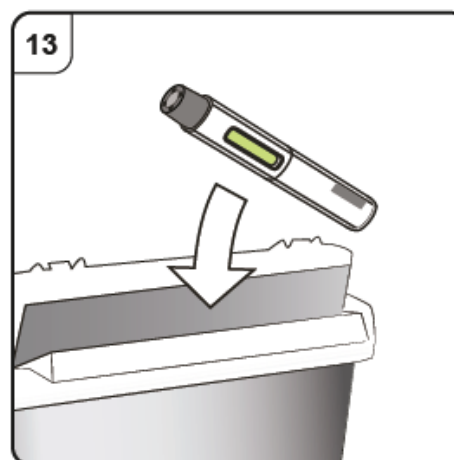

What are possible side effects from using Xolair?

As with all medicines, patients treated with Xolair can experience side effects.

The side effects caused by Xolair are usually mild. In clinical studies, they were about as common in people who were given Xolair as those who were given a placebo (or dummy) injection that did not contain omalizumab.

Look out for signs of allergic reactions and other serious side effects:

Xolair can potentially cause serious side effects. You must look out for signs of these conditions while you use Xolair. Some patients had a serious allergic reaction called anaphylaxis, occurring at an average of 2 out of 1000 patients (0.2%) or more. Should it happen, anaphylaxis quickly causes symptoms such

as rash, itching, and swelling of the tongue and throat, which can make it hard to breathe and can be life threatening. Seek medical help immediately if you notice any signs indicating a severe allergic reaction or other serious side effects. Such signs are in the “**Serious side effects and what to do about them**” table. Please speak with your doctor about this information.

It is important that you receive training from your healthcare professional in how to recognize early signs of severe allergic reactions, and how to manage these reactions if they occur (see **How to take Xolair** section). The majority of severe allergic reactions occur within the first 3 doses of Xolair.

Take special care if you have a disorder where your own immune system attacks part of your own body (autoimmune disease).

A specific type of allergic reaction (serum sickness) has also been observed in patients treated with Xolair or similar products. Signs include joint pain, stiffness, rash, fever, swollen/enlarged lymph nodes and occur typically within one to five days after the injection. If you have such a reaction after taking Xolair, contact a doctor immediately.

In initial clinical studies in asthma, the number of observed malignancies was uncommon (<1%) in all studied patients who received Xolair or a placebo injection containing no medication, with 0.5% reported in patients receiving Xolair and 0.2% in patients receiving placebo injections. Results from a review of all the clinical trials now completed (double in size from the initial studies) and also results from a 5 year observational study found that Xolair was not associated with an increased risk of malignancy. Please discuss this information with your doctor.

The most common side effects reported in patients who received Xolair in clinical studies in asthma, CRSwNP and CIU are listed below. These are not all the possible side effects you may have when taking Xolair. If you experience any side effects not listed here, tell your healthcare professional.

- Injection-site reaction (bruising, redness, warmth, burning, stinging, or other discomfort around the injection site)
- Viral infections
- Upper respiratory tract infection
- Sinusitis
- Headache
- Sore throat
- Urinary tract infection
- Feeling dizzy
- Abdominal pain

In children 6 to less than 12 years of age with asthma:

- Common cold symptoms
- Headache
- Fever
- Sore throat
- Pain or discomfort of your ear
- Nausea
- Vomiting
- Nose bleeding

Other less commonly observed side effects included pain, broken bones, leg pain, joint pain, muscle pain, joint swelling, and hair loss.

If you notice hives, skin rash, injection site reactions or any side effects not mentioned in this leaflet, please inform your doctor or nurse.

If you experience any of these, tell your doctor straight away.

Serious side effects and what to do about them			
Symptom / effect	Talk to your healthcare professional		Stop taking drug and get immediate medical help
	Only if severe	In all cases	
RARE			
Sudden severe allergic reaction (e.g. anaphylaxis): sudden signs of allergy such as rash, itching or hives on the skin, swelling of the face, lips, tongue or other parts of the body, fast heartbeat, dizziness and light headedness, shortness of breath, wheezing or trouble breathing			✓
Low blood platelet count with symptoms such as bleeding or bruising more easily than normal			✓
Churg-Strauss syndrome: Joint appearance of some of the following symptoms: Pain, numbness or tingling in the arms and legs, lumps or raised patches in the skin, weakness and fatigue, loss of appetite and weight loss			✓
Serum-sickness: Joint appearance of some of the following symptoms: Joint pain, stiffness, rash, fever, swollen/enlarged lymph nodes. When it occurs this is usually between one to five days after injection			✓

If you have a troublesome symptom or side effect that is not listed here or becomes bad enough to interfere with your daily activities, tell your healthcare professional.

Reporting Side Effects

You can report any suspected side effects associated with the use of health products to Health Canada by:

- Visiting the Web page on Adverse Reaction Reporting (<https://www.canada.ca/en/health-canada/services/drugs-health-products/medeffect-canada.html/adverse-reaction-reporting.html>) for information on how to report online, by mail or by fax; or
- Calling toll-free at 1-866-234-2345.

NOTE: Contact your health professional if you need information about how to manage your side effects. The Canada Vigilance Program does not provide medical advice.

Storage:

Xolair is to be stored in a refrigerator (2 to 8°C). Do not freeze. In order to protect from light, store in the original package. Any unused product or waste material should be disposed of in accordance with local requirements. Your doctor or nurse will know this. Do not shake.

Keep out of reach and sight of children.

If you want more information about Xolair:

- Talk to your healthcare professional
- Find the full product monograph that is prepared for healthcare professionals and includes this Patient Medication Information by visiting the Health Canada website: (<https://www.canada.ca/en/health-canada/services/drugs-health-products/drug-products/drug-product-database.html>); the manufacturer's website (www.novartis.ca), Novartis Pharmaceuticals Canada Inc., or by calling 1-800-363-8883.

This leaflet was prepared by Novartis Pharmaceuticals Canada Inc.

Last Revised: Feb 8, 2024

Xolair is a registered trademark.